



Installation & Safety Instructions

FLEX-LIFTER™ CONVEYOR BELT LIFTER



Before operating the Flex-Lifter™, users must read and understand the following instructions.

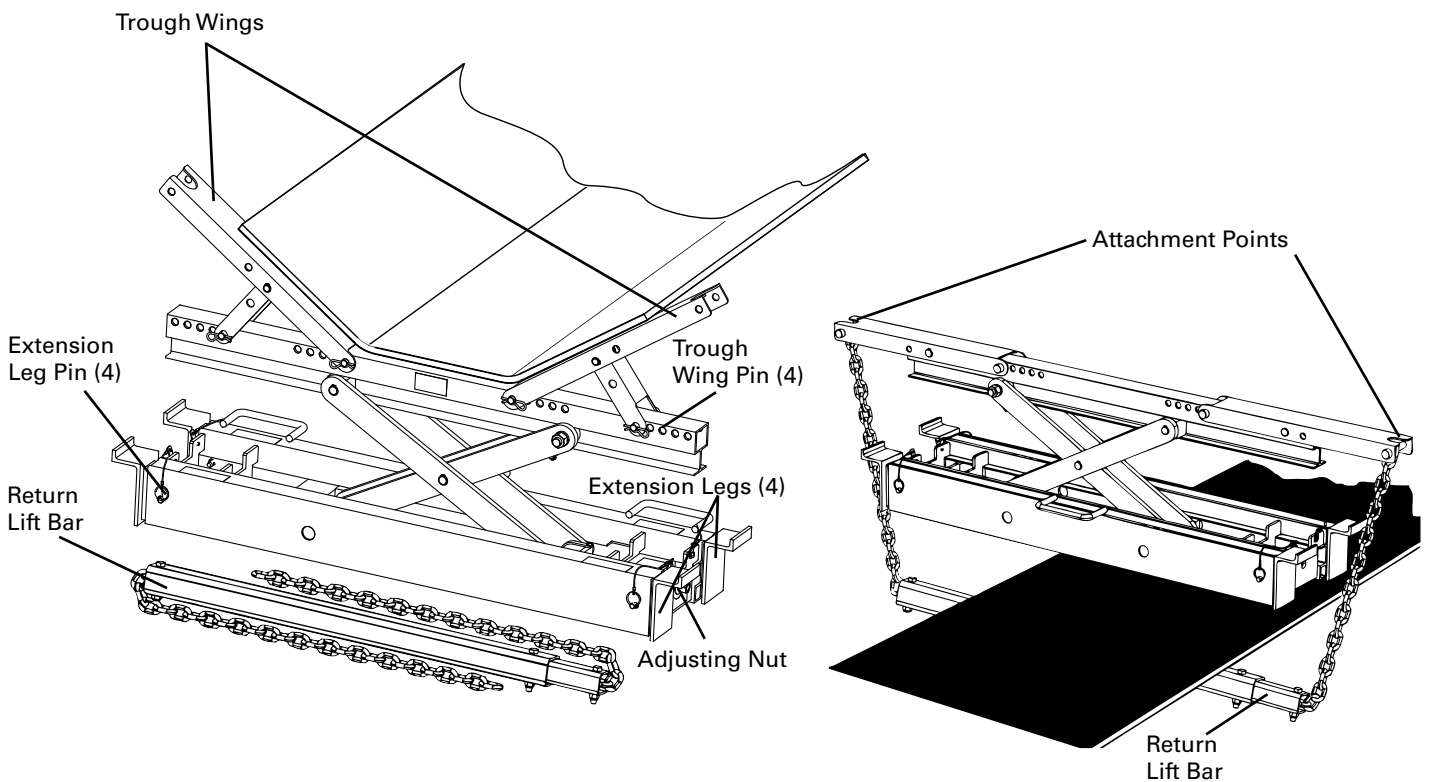

SPECIFICATIONS:

Size	Weight		Model	Part No.	Closed Height		Vertical Lift		Belt Width Range	
	kg.	lb.			mm	in.	mm	in.	mm	in.
Medium	29.9	66	FLM	76979	169	6.75"	350	14	900-1500	36"-60"
Large	35.4	78	FLL	76980	169	6.75"	400	16	1200-1800	48"-72"

⚠ WARNING			
Height		Safe Lifting Capacity	
mm	in.	kg.	lbs.
0 - 25	0 - 1	225	500
25 - 50	1 - 2	450	1000
50 - 75	2 - 3	675	1500
75 - 100	3 - 4	900	2000
100 - 125	4 - 5	1150	2500
125 - 150	5 - 6	1350	3000
150 - 175	6 - 7	1600	3500
>175	>7	1800	4000

- Load Must Be Centered
- Do Not Exceed Capacity
- Collapsing Belt Lifter May Injure or Kill Operators

⚠ DANGER

Crushing Hazards: Unexpected belt movement will topple Flex-Lifter™ and create in-running nip points. To prevent serious injury or death, OSHA Lock-out/Tag-out rules must be followed:

- Place individual padlocks on conveyor power source before belt lifting operations.
- Securely clamp belts on sloped conveyors to prevent movement (see Far-Pul™ HD® Belt Clamps).

⚠ WARNING

Lift Collapse Hazard: Severe and Fatal Injuries may occur. To prevent loss of structural integrity:

- Flex-Lifter™ must only be used to lift conveyor belts - Do Not Lift personnel, vehicles, or other equipment with this dedicated lifting device.
- Follow Safe Lifting Capacity Warning
- Flex-Lifter™ loading Must Not Exceed 1800 kg. (4000 lb.) To reduce or restrict loading:
 - Remove conveyed material
 - Lower belt tension
 - Use short lift heights
 - Restrict torque from drills, impact wrenches, and cheater bars
 - Stay at least 6.2M (20 ft.) away from head or tail pulleys

⚠ WARNING

Shear Hazard: Raising and Lowering the Flex-Lifter™ creates scissor and squeezing actions that can cut and crush limbs. Keep body parts away from lifter during operation.

⚠ CAUTION

Do not overdrive when lowering the unit. Could damage cranking mechanism. Clean and lubricate drive components of lifter regularly to extend optimal performance.

⚠ DANGER

Catastrophic Fractures: Do Not Use broken, bent, fractured, or worn belt lifters. Sudden structural collapse will injure or kill the operators. Call the factory for a free “loaner” Flex-Lifter™ and arrange a “Factory Repair” of your Flex-Lifter™. Do Not Weld the high strength aluminum members. Do Not Cut or Drill the components. Almost all the standard repair procedures will weaken the belt lifter. Examine the belt lifter before each use to assure its integrity.

⚠ WARNING

Body Strains: The medium and large Flex-Lifter™ weigh 29.9kg. (66lb.) and 35.4kg. (78lb.) respectively; they are constructed from lightweight high strength aluminum members. Use two workers to deploy and remove the belt lifter from awkward setups to avoid muscular and skeletal injuries.

⚠ CAUTION

The on-product warning decals are important safety aids, especially to new users of the Flex-Lifter™. Damaged warning decals will be replaced without charge by contacting Flexco. Additional copies of this instruction set are available on-line or through your Flexco dealer. It is important for user safety to retain these instructions for training and re-training operators.

Tools Needed:

- 19mm (3/4") Socket
- Ratchet, Drill Motor or Impact Wrench

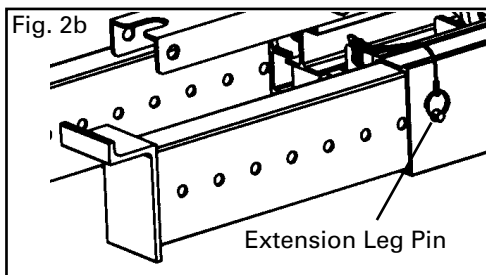
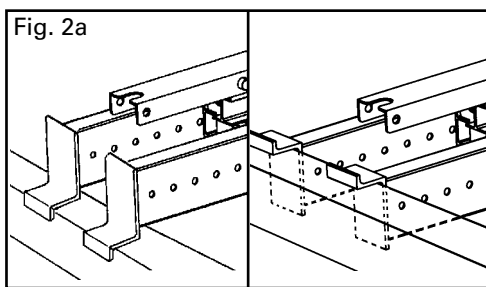
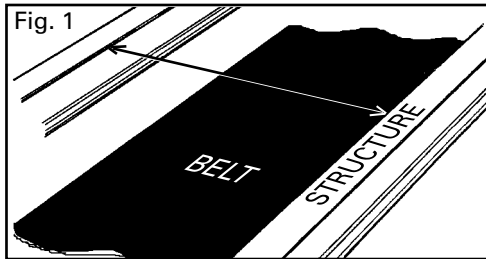

STEP 1. Measure conveyor width. After determining the area of the conveyor where the Flex-Lifter™ will be used, measure the inside width of the main conveyor structure (Fig. 1)

STEP 2. Pre-set the Lifter Extension Legs. Using the above measurement, adjust the extension legs to a length that will allow the legs to sit safely on the structure and allow for a centered load. **NOTE:** The extension legs can be positioned either to be resting on top of the structure (if more lift height is needed) or down inside the structure (Fig. 2a). To adjust the extension legs, simply remove the extension leg pin and slide the leg in or out as required. Adjust the two legs on each side to the same length so both legs will rest on the structure (Fig. 2b). Replace extension leg pin after adjusting leg position.

STEP 3. Position the lifter onto the conveyor. After presetting the extension legs to fit the conveyor structure, safely slide the lifter across the conveyor and position it squarely onto the structure, making sure load is centered above the lifter.

Top Side Operation (For Return-Side Operation; Go to Step 8. For Flat Belts; Go to Step 5.)

STEP 4. Set Trough Wings. Remove the outer trough wing pin and lift the trough wing to allow the inner brace to swing out. Reinsert the trough wing pin to hold it in place (Figs. 4a & 4b). Repeat on opposite end. Trough wings should be set to match the idler configuration. The lifter top bar contains two hole sets (five holes each) at each end. By removing both trough wing pins, the inside wing pivot point may be changed to match the idler junction.

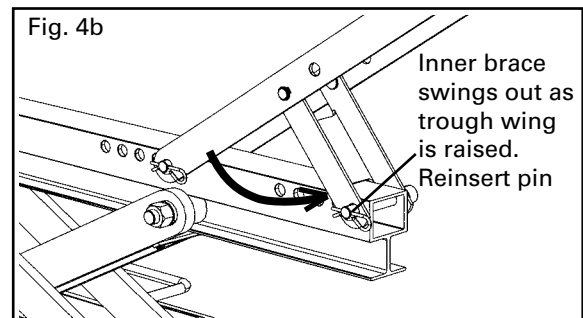
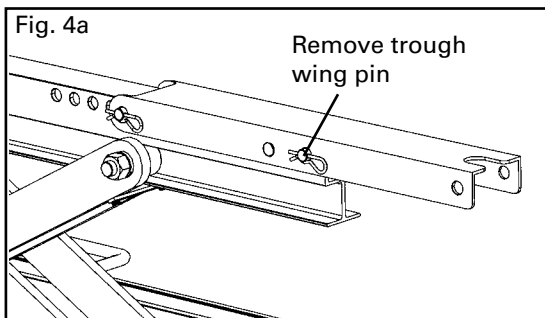

STEP 5. Lift the belt. Turn the adjusting nut counter-clockwise until the belt is at the desired height. (Use the correct size socket and tool - not included.) Remove the ratchet or power tool prior to starting work.

⚠ DANGER

Pinch points - Use caution when raising and lowering the Flex Lifter™.

STEP 6. Lower the belt. Once work is completed, reconnect the ratchet or power tool to the adjusting nut and turn in a clockwise direction until the lifter is completely retracted to its lowest position.

⚠ WARNING

Do not overdrive when lowering the unit. Could lead to damage.

STEP 7. Remove the lifter. As in Steps 3 & 4, remove the wing pins, lower the trough wings to the flat position and re-insert the wing pins. Safely slide the lifter from the structure and position the extension legs to their innermost position for safe transporting and storage.

Return Side Operation:

STEP 8. Configure Return Lift Bar. Adjust length of Return Lift Bar to match belt width. Be sure to re-insert and tighten Adjustment Bolt.

STEP 9. Attach Return Lift Bar. Position and center Return Lift Bar below conveyor belt. Move Trough Wing Pins to Attachment Point Holes and secure Lift Bar Chains in place. Adjust Trough Wings inboard or outboard, as necessary, to align chains with Return Lift Bar. Chains should be vertical, or nearly vertical. (See Figs. 8a and 8b.)

⚠ WARNING

Attachment Point Maximum Load – 225kg (500 lbs)
Collapsing Belt Lifter May Injure or Kill Operators.

⚠ WARNING

Return Bar to be used only with Flex-Lifter to lift conveyor belts. Do not use for hoisting.

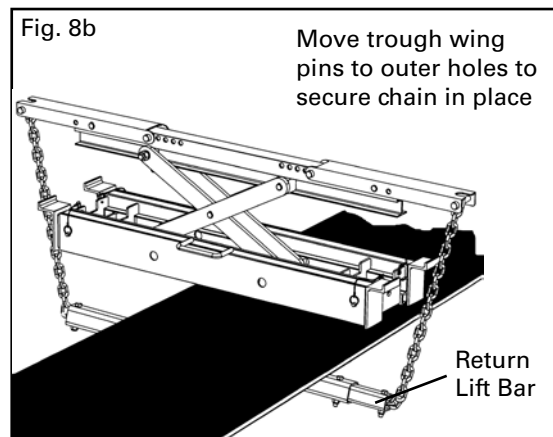
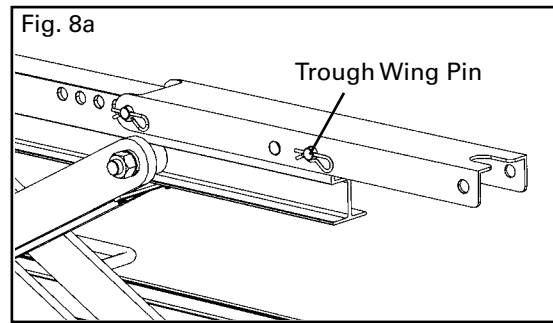

STEP 10. Lift the Belt. Turn the Adjusting Nut counter-clockwise until the belt is at the desired height. (Use the correct size socket and tool—not included.) Remove the ratchet or power tool prior to starting work.

⚠ DANGER

Pinch Points – Use caution when raising and lowering the Flex-Lifter.

STEP 11. Lower the belt. Once work is completed, reconnect the ratchet or power tool to the Adjusting Nut and turn in a clockwise direction until the Flex-Lifter is completely retracted to its lowest position.

⚠ WARNING

Do not overdrive when lowering the unit. Could lead to damage.

STEP 12. Remove the Flex-Lifter. Disconnect Return Lift Bar from Attachment Points. Re-position Trough Wing Pins to original position. Safely slide the Flex-Lifter from the structure and position the extension legs to their innermost position for safe transporting and storage.